

Denoting by

$$\langle f(r) \rangle = 4\pi \int_0^\infty f(r)p(r,t)r^2 dr$$

one finds now by multiplying eq A1 by r and r^2 and integrating by parts that

$$\begin{aligned} \frac{d\langle r \rangle}{dt} &= \frac{D}{kT} \langle F(r) \rangle + 2D \left\langle \frac{1}{r} \right\rangle \\ \frac{d\langle r^2 \rangle}{dt} &= 2D \left[3 + \frac{1}{kT} \langle rF(r) \rangle \right] \end{aligned} \quad (\text{A2})$$

essentially similar relations to our previous linear (one-dimensional) Smoluchowski equation results (3 and 4). The term $2D\langle 1/r \rangle$ prevents loss of particles to a necessary singularity at the origin. To see the similarity of the predictions of these equations to those of eq 3 and 4 consider the special case when eq A2 can be exactly integrated, say when $F(r) = -\gamma r$. For mathematical simplicity we set $R_0 \sim r_0 \sim 0$ and compare with eq 8. From eq A2 we have

$$\frac{d\langle r^2 \rangle}{dt} = 2D \left[3 - \frac{\gamma}{kT} \langle r^2 \rangle \right]$$

Thus

$$\sqrt{\langle r^2 \rangle} = r(\tau) = \sqrt{\frac{3kT}{\gamma} [1 - e^{-2D\gamma\tau/kT}]} \quad (\text{A3})$$

which differs only by the factor $\sqrt{3}$ from eq 8. In view of the many approximations inherent in our starting formula such a numerical factor is negligible.

References and Notes

- (1) R. M. Noyes, *Prog. React. Kinet.*, **1**, 131 (1961).
- (2) T. Koenig, *J. Am. Chem. Soc.*, **91**, 2558 (1969).
- (3) A. Stevani, G. Thrower, and C. F. Jordan, *J. Phys. Chem.*, **73**, 1257 (1969).
- (4) K. Chakravortz, J. M. Person, and M. Szwarc, *J. Am. Chem. Soc.*, **90**, 283 (1968); *Int. J. Chem. Kinet.*, **1**, 357 (1969), and papers by M. Szwarc presented at the 160th National Meeting of the American Chemical Society, Chicago, Ill., Sept 1970.
- (5) W. Braun, L. Rajenback, and F. Eirich, *J. Phys. Chem.*, **66**, 1591 (1962).
- (6) T. Koenig and H. Fischer in "Free Radicals", Vol. I, J. K. Kochi, Ed., Wiley, New York, N.Y., 1973, Chapter 4.
- (7) T. Koenig and M. Deinzer, *J. Am. Chem. Soc.*, **90**, 7014 (1968). Recent calculations in Koenig et al. show that this limiting formula can be only a rough limiting approximation.
- (8) P. A. Carapellucci, *J. Am. Chem. Soc.*, **97**, 1278 (1975).
- (9) M. Szwarc, private communication.
- (10) For a kinetic approach to this general problem see W. A. Pryor and K. Smith, *J. Am. Chem. Soc.*, **92**, 5403 (1970).
- (11) H. G. Kuivila and K. R. Wursthorn, *Tetrahedron Lett.*, 4557 (1975).
- (12) H. G. Kuivila and D. Rosenberg, unpublished.
- (13) Although the evidence is compelling that arylsodium is involved in the reaction, the evidence that it is actually formed in the cage would bear more definitive experimental support than is now available.

Photodetachment of Electrons from Enolate Anions. Gas Phase Electron Affinities of Enolate Radicals

Albert H. Zimmerman,^{1a} Kenneth J. Reed,^{1b} and John I. Brauman*

Contribution from the Department of Chemistry, Stanford University, Stanford, California 94305. Received March 16, 1977

Abstract: Photodetachment cross sections are measured as a function of photon energy for enolate anions formed by proton abstraction in the gas phase, using an ion cyclotron resonance spectrometer to trap and detect the ions. Electron affinities are determined from the photodetachment thresholds for the enolate anions from acetaldehyde, propionaldehyde, butyraldehyde, 3-pentanone, pinacolone, methyl acetate, acetophenone, 4-heptanone, 1,1,1-trifluoroacetone, diisopropyl ketone, phenylacetaldehyde, acetyl fluoride, acetone, 3,3-dimethylbutanal, and 2-butanone. The cross section shapes are analyzed in terms of a theoretical model for photodetachment, and we conclude that each cross section is composed of many vibronic transitions. We find evidence for electronic transitions in some of these anions in the blue and UV regions of the spectrum. Finally, substituent effects on anion stabilities are discussed and compared with the corresponding effects in solution.

The reactions of enolate anions are of major importance in synthetic organic chemistry as well as in the study of organic reaction mechanisms. An understanding of their thermochemical and spectroscopic properties is useful both in devising synthetic schemes employing enolate anions and in mechanistic studies of reactions involving enolate anions. The thermodynamic stability of an enolate anion is reflected in the acidity of its parent carbonyl compound. Since the acidity is strongly dependent on the relative solvation of the anion and the neutral compound, it is often difficult to evaluate the intrinsic effects of small changes in molecular structure on the stabilities of anions in solution. It is not unusual that small changes in the stabilities of anions in solution may be completely dominated by large variations in the degree of their solvation. For example, the acidity order observed in solution is reversed from that observed in the gas phase for aliphatic alcohols.² Although the acidities of some simple carbonyl compounds have been measured in solution,^{3,4} in most cases it is difficult to determine to

what extent acidity changes are the result of solvation effects.

Recent measurements by Kebarle and co-workers⁵ of the acidities of some carbonyl compounds in the gas phase have been used to note substituent effects on the stabilities of enolate anions. While the application of these acidity measurements to simple carbonyl compounds was limited to acetone, acetophenone, and trifluoroacetone, they clearly showed the potential of the technique for investigating the intrinsic thermodynamic stabilities of these compounds. Grunwell and Sebastian⁶ have made a CNDO/2 study of the relative stabilities of the two possible enolate anions derived from 2-butanone, finding the most highly substituted anion to be energetically more stable by 11.0 kcal/mol. However, it is not clear that CNDO is capable of accurately predicting small changes in stability, especially when variations from "standard" geometries are not considered.

The object of this work was to investigate the stabilities of

simple enolate anions in the gas phase through measurement of the energy requirements for photodetachment of an electron.

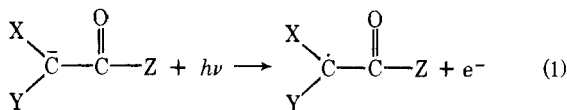

If the enolate anion is in its ground state, the minimum photon energy required for this process corresponds to the electron affinity of the enolate radical. The electron affinity is thus a measure of the energetic stability of the enolate anion relative to the radical. The acidity of the parent carbonyl compound (the enolate anion is formed from the parent carbonyl compound by removal of a proton on the α -carbon atom), however, is a measure of the stability of the enolate anion relative to that of the parent carbonyl. These two measures of stability are closely related, the acidity (ΔH°) of the parent carbonyl compound being the difference between the $\alpha\text{C-H}$ bond dissociation energy and the electron affinity of the enolate radical, plus the ionization potential of hydrogen: $\text{DH}^\circ(\alpha\text{C-H}) - \text{EA}(\text{radical}) + 313.6 \text{ kcal/mol}$. Measurements of electron affinities may therefore either give stabilities of enolate anions with respect to loss of an electron, or, if the $\alpha\text{C-H}$ bond dissociation energy is known, give the acidities of the parent carbonyl compounds. This provides the alternative possibility of combining gas phase acidity measurements with electron affinities to obtain bond dissociation energies.^{7b}

The intimate relationship between electron affinities, bond dissociation energies, and acidities suggests that substituent effects on each of these quantities should be an important source of information concerning electronic structure and bonding. We may look at several types of substituent effects which are important in determining the stability of anions and neutrals. The first and largest effect is caused by changing the electron-attracting nature of the center on which the electron resides in the anion.^{7a} Increasing the electron-attracting nature, as in the series CH_4 , NH_3 , H_2O , HF , causes a large increase in electron affinity, a smaller increase in bond energy, and thus a net increase in acidity. A second effect corresponds to substitution of a dipolar group such as CF_3 . The resultant inductive effect will greatly increase the electron affinity without appreciably affecting the bond strength, thereby increasing the acidity. Here the increase in electron affinity is determined by the magnitude and direction of the group dipole.² A third effect arises when a large alkyl group is substituted for a small one.^{2,7b} Here, due to polarizability or delocalization, the electron affinity increases. Since the bond energy remains essentially constant, the acidity increases. Finally, when hydrogen is replaced by methyl on an unsaturated carbon, the EA typically decreases. The bond strength may be lowered by this substitution as well, so that the overall acidity may be only slightly affected as in the case of 5-methylcyclopentadiene.^{7c}

In this paper we report the relative photodetachment cross sections as a function of photon wavelength for several representative enolate anions. The photodetachment threshold wavelengths are determined, and from them we have obtained the electron affinities of the corresponding enolate radicals. The effects of vibrational hot bands are evaluated in some model systems by observing how changes in the internal energy of the anions affect the photodetachment thresholds. Finally, we note and discuss the effects of substituents on electron affinities and stabilities in the gas phase, and compare these effects with those observed in solution.

Experimental Section

Instrumentation. A Varian V-5900 ion cyclotron resonance spectrometer with a modified square cell design⁸ was used to form and trap

the enolate anions. Cell conditions were chosen to maximize trapping times; typically high trapping potentials (1.80–3.00 eV), moderate source drift potentials (0.10–1.00 eV), and low analyzer drift potentials (<0.2 eV) were used. With neutral gas pressures of about 1×10^{-6} Torr, trapping times of 0.5–1.0 s were typically observed for these ions.

For all the results reported here the enolate anions were formed by proton transfer from the parent carbonyl compounds to F^- . The F^- was produced by electron impact from either NF_3 at an electron energy of 1.7 eV, or SO_2F_2 at an electron energy of 4.0 eV (electron energy minus trapping). The use of F^- as a precursor to the enolate anions is particularly convenient since the photodetachment threshold of F^- is at about 350 nm.⁹ Therefore no decreases in enolate ion concentration in the visible region of the spectrum are observed due to detachment of F^- . Ion ejection^{10a} and double resonance^{10b} experiments showed that the observed photodestruction of enolate anions did not arise from photodetachment of any other precursor ions.

The light source was a 1000-W xenon arc lamp used in conjunction with a grating monochromator. The data points above 400 nm have a spectral resolution (fwhm) of 23.8 nm while those below 400 nm have a resolution of 14.1 nm. Our estimate of the maximum error in the monochromator readings is ± 3 nm. Maximum photodecreases in anion signals ranged from 7 to 10% for all the anions except acetophenone enolate (16%). Detailed explanations of the data collection and analysis have been previously reported.⁷

Materials. The following parent carbonyl compounds were used after vacuum distillation to generate the enolate anions: acetaldehyde, propionaldehyde, butyraldehyde, 3-pentanone, pinacolone, methyl acetate, acetophenone, 4-heptanone (all MCB), 1,1,1-trifluoroacetone, diisopropyl ketone, phenylacetaldehyde (all Aldrich), acetyl fluoride (PCR), acetone (Baker), 3,3-dimethylbutanal, and 2-butanone-3,3- d_2 . 3,3-Dimethylbutanal was synthesized by reaction of $\text{Na}_2\text{Fe}(\text{CO})_4 \cdot 1.5$ dioxane with neopentyl bromide in a solution of triphenylphosphine in 1-methyl-2-pyrrolidinone.¹¹ After acidification with acetic acid, the aldehyde was codistilled with dioxane from the reaction mixture. The distillate contained only 3,3-dimethylbutanal and dioxane by GLC. Dioxane produces no negative ions under our experimental conditions, and no attempt was made to purify the aldehyde further. Since there are two different α -carbon positions in 2-butanone, proton abstraction may result in two chemically distinct enolate anions of the same mass. Selective deuteration to form 2-butanone-3,3- d_2 allows mass differentiation between these two enolate anions. The deuterated 2-butanone was synthesized from 3,3-dibromo-2-butanone using a zinc-copper couple.¹² The 3,3-dibromo-2-butanone was prepared by the reaction of 2-butanone with *N*-bromosuccinimide.¹³ The deuterated ketone was 90% isotopically pure (by mass spectroscopy). The photodetachment spectra of the two chemically distinct enolate anions from the deuterated ketone corresponding to m/e 72 (internal enolate anion) and 73 (external enolate anion) were measured. The rates of proton transfer reactions involving these ions and 2-butanone are slow enough ($\sim 0.2 \times 10^{-11} \text{ cm}^3 \text{ molecule}^{-1} \text{ s}^{-1}$) so that at 10^{-6} Torr little coupling between the two enolate anions will occur.¹⁴

Results

The photodestruction cross sections for the enolate anions from acetaldehyde, acetone, and propionaldehyde are shown in Figures 1–3, respectively. Each of these anions was formed using F^- from two different sources, NF_3 and SO_2F_2 , as indicated. The cross section thresholds for these anions appear to shift slightly to higher energy when SO_2F_2 is used as the source of F^- . Similar cross sections were measured for enolate anions from pinacolone, 2-butanone-3,3- d_2 (m/e 72 and 73), 3-pentanone, 3,3-dimethylbutanal, butyraldehyde, 4-heptanone, diisopropyl ketone, methyl acetate, acetyl fluoride, and 1,1,1-trifluoroacetone. Figure 4 shows the photodestruction cross section for the phenylacetaldehyde enolate anion. Similar results were obtained for the enolate anion from acetophenone.

The photodestruction of enolate anions as a function of photon wavelength was also investigated with the xenon arc lamp used in conjunction with long-pass interference filters. Using the high photon flux available with filters, the threshold wavelengths were estimated within ± 25 nm. In all cases

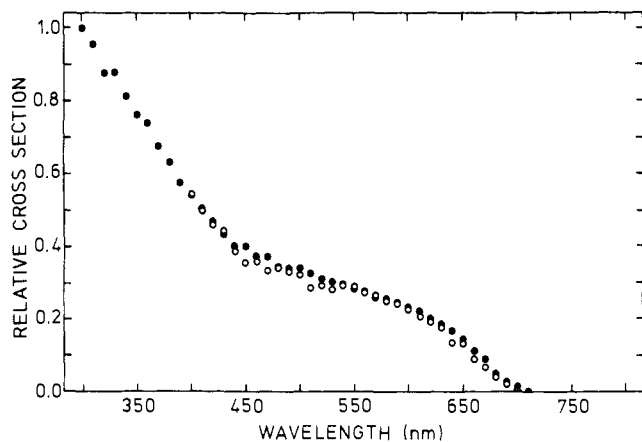

Figure 1. Relative photodetachment cross sections for acetaldehyde enolate anion (●) generated using F^- from NF_3 , and (○) generated using F^- from SO_2F_2 .

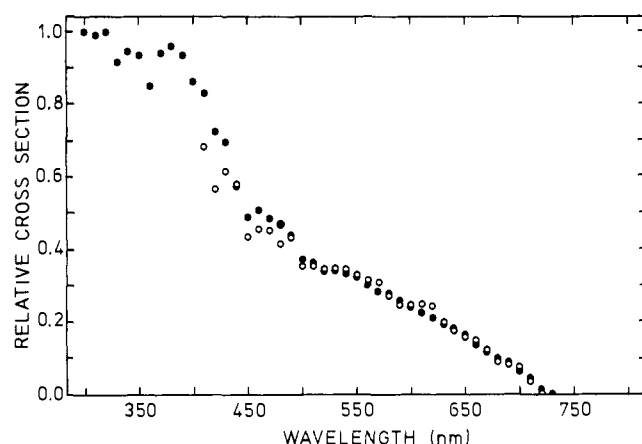

Figure 2. Relative photodetachment cross sections for acetone enolate anion (●) generated using F^- from NF_3 , and (○) generated using F^- from SO_2F_2 .

threshold wavelengths measured with the monochromator were consistent with those estimated with long-pass filters. When the enolate anions were irradiated with light above 300 nm in wavelength no new ions appeared in the mass spectrum, indicating that photodissociation does not occur at these wavelengths. When CCl_4 was used to scavenge detached electrons¹⁵ from acetone and acetophenone enolate anions, the cross section for Cl^- production was identical with that for enolate anion destruction above 350 nm. This is evidence that the photodestruction cross sections reported here correspond to the photodetachment cross sections of the enolate anions.

The photodetachment thresholds for the anions studied are given in the first column of Table I. These thresholds correspond to estimates of the zero intercept for each cross section, and typically have an uncertainty of ± 5 to ± 7 nm depending on signal to noise near threshold. Since each threshold includes instrumental broadening, the spectral bandwidth (24 nm) was subtracted from each observed threshold. The corrected threshold corresponds to the electron affinity of the enolate radical within the bandwidth of the monochromator, unless appreciable hot bands are present. In column 2 of Table I the energies corresponding to the corrected thresholds are tabulated, the error limits corresponding to ± 24 nm. The thresholds obtained when the anions were generated with F^- from SO_2F_2 are in parentheses in each column. Only selected ions were generated using F^- from SO_2F_2 since ion signals were much poorer, and maximum fractional signal decreases were about

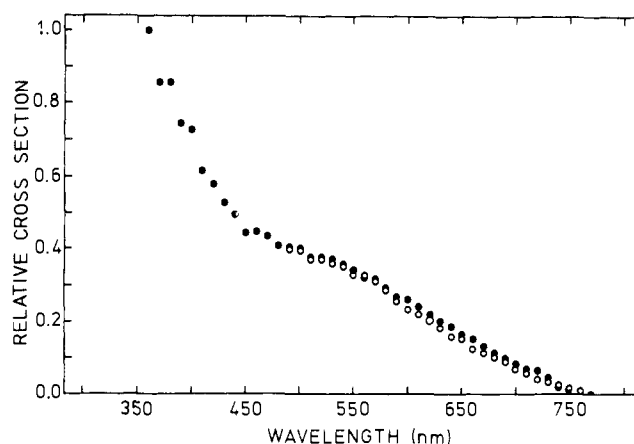

Figure 3. Relative photodetachment cross sections for propionaldehyde enolate anion (●) generated using F^- from NF_3 , and (○) generated using F^- from SO_2F_2 .

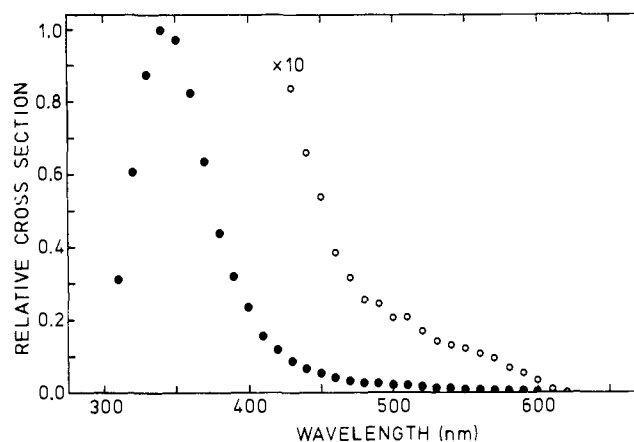

Figure 4. Relative photodetachment cross section for phenylacetaldehyde enolate anion formed using F^- from NF_3 . The data from 430 nm to threshold (○) are shown multiplied by ten.

half those obtained when the ions were formed using F^- from NF_3 .

Discussion

Each of the photodetachment cross sections we have measured is a superposition of rotational,¹⁶ vibrational,¹⁷ and electronic¹⁸ transitions between the enolate anion and the radical. The rotational transitions will not be considered since they are very closely spaced in these molecules and, therefore, will only broaden each vibrational transition slightly. This broadening will have little effect with our low spectral resolution. The relative intensities of the vibrational transitions are governed by the overlap between the anion and radical vibrational wave functions (Franck-Condon factors), as well as the energy distribution among the vibrational levels of the anion. Before we examine the factors which lead to off-diagonal Franck-Condon transitions and vibrational hot bands, it is worthwhile to examine from a theoretical point of view the dependence on photon energy of a single isolated photodetachment transition cross section.

Threshold Shapes. The photodetachment cross section at threshold may be written as a power series in $E - E_0$ where E is the photon energy and E_0 is the threshold energy.¹⁹

$$\sigma(E) = \sum_{l=0}^{\infty} A_l (E - E_0)^{l+1/2} [1 + O(E - E_0)] \quad (2)$$

Here \hbar is the angular momentum of the detached electron and resultant neutral relative to their common center of mass, and

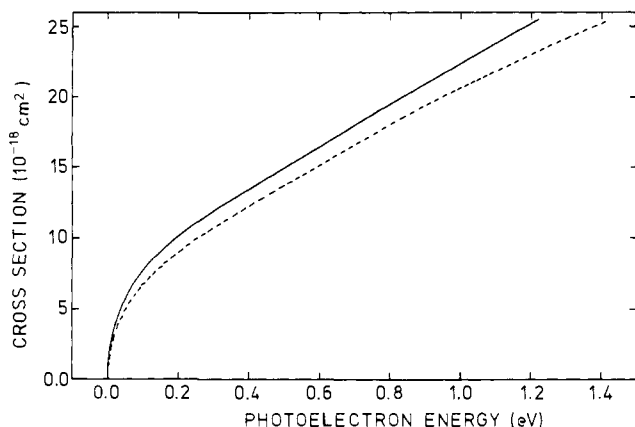

Figure 5. Calculated photodetachment cross sections for acetaldehyde enolate anion (—) and propionaldehyde enolate anion (---). The photon energies at zero photoelectron energy are 1.81 and 1.69 eV, respectively.

the A_l are constants. This expansion is general at threshold assuming²⁰ that the interactions between the detached electron and the resultant radical fall off faster than r^{-2} . The electronic transition moment for a single vibrational rotational photodetachment transition is given to first order by the square of the dipole matrix element of the wave function of the HOMO of the anion and a free electron wave function. For any anion with C_s or lower symmetry the initial state of the anion always transforms as a p_x , p_y , or p_z basis function. Thus the dipole selection rule $\Delta l = \pm 1$ indicates that the lowest allowed angular momentum of the detached electron must be zero, corresponding to an s wave ($l = 0$). Therefore the photodetachment cross section for any anion of C_s or lower symmetry will be discontinuous and proportional to $(E - E_0)^{1/2}$ at threshold. All of the enolate anions studied here fall into this symmetry category.

It is instructive to compare the threshold behavior of enolate anions with that of allyl anion.²¹ Because of the C_{2v} symmetry of allyl anion, the lowest allowed angular momentum of the detached electron is 1, giving a slowly rising cross section proportional to $(E - E_0)^{3/2}$ at threshold. This means that A_0 in eq 2 is identically zero for symmetry reasons. If the symmetry of allyl anion is then slightly perturbed from C_{2v} symmetry, A_0 is no longer identically zero and the cross section suddenly becomes discontinuous at threshold. But if the perturbation is small the discontinuity at threshold will be small in magnitude (because A_0 is small) and will be followed at higher energy by a much more intense, slowly rising cross section. The highest occupied molecular orbital (HOMO) of an enolate anion is qualitatively similar to that of allyl anion except that greater electron density exists on oxygen than on the α carbon, and the nodal plane is shifted slightly toward oxygen in the enolate anion. If any enolate anion is regarded as a perturbed allyl system, we can predict from symmetry alone that the photodetachment cross section will continue rising slowly with increasing energy after an initial, discontinuous rise at threshold.

We may calculate the photodetachment cross section as a function of energy by actually evaluating the dipole matrix element of the transition.¹⁹ To make this calculation tractable for large systems we assume that photodetachment is a simple one-electron transition from the ground electronic state of the anion to the ground electronic state of the neutral and free electron. These assumptions employ the Born-Oppenheimer separation of electronic from nuclear coordinates and neglect the short-range interactions which exist between the detached electron and the resultant neutral. The implicit assumption is made that no orbital reorganization occurs in the transition

Table I. Photodetachment Thresholds for Substituted Enolate Anions^a

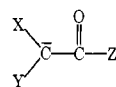
				Photo-detachment threshold, nm	E_0 , kcal/mol
	X	Y	Z		
1.	H	H	H	710 (700)	41.7 (42.3) \pm 1.4
2.	H	H	CH ₃	728 (718)	40.6 (41.2) \pm 1.3
3.	H	H	CD ₂ CH ₃	733	40.4 \pm 1.3
4.	H	H	<i>t</i> -Bu	697 (682)	42.5 (43.3) \pm 1.5
5.	H	H	OCH ₃	714	41.5 \pm 1.4
6.	H	H	CF ₃	505	59.5 \pm 2.9
7.	H	H	F	583	51.2 \pm 2.1
8.	H	H	C ₆ H ₅	625	47.6 \pm 1.8
9.	D	CH ₃	CH ₃	765	38.6 \pm 1.2
10.	H	CH ₃	CH ₂ CH ₃	762 (760)	38.8 (38.9) \pm 1.2
11.	H	CH ₂ CH ₃	CH ₂ CH ₂ CH ₃	745	39.7 \pm 1.3
12.	H	CH ₃	H	760 (760)	38.9 (38.9) \pm 1.2
13.	H	CH ₂ CH ₃	H	768	38.5 \pm 1.2
14.	H	<i>t</i> -Bu	H	705	42.0 \pm 1.4
15.	H	C ₆ H ₅	H	614	48.5 \pm 1.9
16.	CH ₃	CH ₃	CH(CH ₃) ₂	870	33.8 \pm 1.0

^a Enolates generated via F⁻ from NF₃. Data in parentheses for enolates generated via F⁻ from SO₂F₂.

from anion to neutral. For the initial state one-electron wave function we use the HOMO of the anion obtained from a CNDO/2 calculation.²² The Slater type orbital exponents are modified to better characterize the diffuse outermost orbital of the negative ion. The modified orbital exponents were determined by fitting the experimental atomic photodetachment cross sections¹⁹ of H⁻, C⁻, and O⁻, and are H = 0.32 au⁻¹, C = 0.56 au⁻¹, and O = 0.68 au⁻¹. The wave function which we use for the free electron is a plane wave orthogonal to the HOMO of the anion. The details involved in calculating the dipole matrix element have been previously described.¹⁹

We have calculated photodetachment cross sections as a function of energy for the enolate anions from acetaldehyde, acetone, and propionaldehyde. Figure 5 shows the cross sections as a function of $E - E_0$ for acetaldehyde and propionaldehyde enolates. That for acetone enolate was essentially identical with the cross section for acetaldehyde enolate. The HOMO coefficients were calculated using CNDO/2 and standard geometries for the anions. Optimizing the geometry of acetaldehyde enolate anion had little effect on the form of its HOMO; thus we conclude that geometry optimization will have little effect on the overall cross section shapes. Both of the cross sections in Figure 5 show sharp thresholds followed by a more slowly rising cross section as expected from the preceding symmetry considerations. The sharp threshold, as expected on the basis of symmetry, is caused by a substantial s wave cross section, while the gradual rise above threshold results from the more slowly rising p wave cross section. In acetone enolate the methyl group is on the carbonyl carbon near the nodal plane in the HOMO. Thus little electron density in the HOMO is delocalized into the methyl group, and the cross section is practically identical with that for acetaldehyde enolate anion. In propionaldehyde enolate anion a methyl group is substituted at the α carbon which carries a high electron density in the HOMO. Thus significant electron density is delocalized onto the methyl group hydrogens. This results in some p wave ($l = 1$) contribution to the cross section and a small decrease in the s wave contribution by slightly shifting the charge distribution. The overall result, however, is that only the absolute magnitude of the cross section for propionaldehyde enolate is significantly different from that for acetaldehyde enolate; the relative cross sections are almost identical. This behavior is in marked contrast to that observed for alkoxy

anions^{17b} where a methyl group exerts a fairly large perturbation above threshold on the relative cross section of O⁻. For enolate anions the methyl group exerts a perturbation on an admixture of s and p wave cross sections which is strongly energy dependent even far above threshold. However, for the methoxyl anion the perturbation is exerted on an s wave cross section which is almost energy independent even far above threshold. Therefore in interpreting experimental photodetachment cross sections of enolate anions we would not expect any large changes in the intrinsic energy dependence of a photodetachment threshold upon substitution, particularly upon substitution at the carbonyl carbon.

In calculating the energy dependence of the cross section we have neglected the effects due to the interaction of the detached electron with the dipole moment of the resultant radical. This is a charge-dipole potential and will depend on r^{-2} , thus being comparable in range to the angular momentum barrier. Calculations have shown that inclusion of an additional r^{-2} interaction potential will modify the threshold law for photodetachment from atomic anions such that the cross section at threshold will rise more sharply with energy.²³ We are presently engaged in measuring high-resolution thresholds for some enolate anions. These measurements may give an indication of how important additional charge-dipole interactions are in their effects on threshold shapes.

Analysis of Threshold Transitions. On the basis of the calculated cross section shapes, the differences between the photodetachment cross sections of acetaldehyde, acetone, and propionaldehyde enolates (Figure 1-3) seem likely to be due to differing degrees of off-diagonal Franck-Condon transitions and hot bands. To have large off-diagonal Franck-Condon factors it is necessary that the geometry of the anion be substantially different from that of the radical. The experimental evidence in Figures 1-3 indicates the Franck-Condon factors becoming more off-diagonal as one proceeds from acetaldehyde to acetone to propionaldehyde enolate anions. The result is increasingly slowly rising cross sections for this series of anions owing to the transition intensities being spread over a wider manifold of vibronic transitions. We also note that propionaldehyde enolate anion has one of the most shallowly rising cross sections of all the enolate anions investigated here, and thus may have severe geometry changes between anion and radical.

To obtain a rough idea of the geometry changes involved we have calculated energy optimized geometries of acetaldehyde enolate anion and radical using CNDO. The results of these calculations are presented in Table II. The only large geometry change is in the C-C-O angle, angle d, which is about 9° greater in the anion than in the radical. Calculation of the Franck-Condon factors for a photodetachment transition requires a detailed knowledge of the normal coordinates as well as the force fields for nuclear motion in both the anion and radical. We have not attempted this calculation, and may therefore only conclude that the Franck-Condon factors could indeed be quite off-diagonal for any normal modes which involve distortion of angle d. Acetone and propionaldehyde enolates might analogously be expected to exhibit large geometry changes in bending modes, and therefore experimentally show an even more slowly rising cross section than does acetaldehyde enolate anion.

The presence of large off-diagonal Franck-Condon factors coupled with appreciable populations in excited vibrational states would result in significant hot band contributions to the photodetachment cross sections. At our typical operating pressure of 10⁻⁶ Torr an enolate anion will undergo only about 20-25 collisions in a lifetime of 500 ms.²⁴ If the anions are formed with excess internal energy they will have only modest opportunity to undergo collisional relaxation. An important problem in using F⁻ from NF₃ to generate anions is that it

Table II. Results of CNDO/2 Geometry Optimizations for Acetaldehyde Enolate Anion and Radical

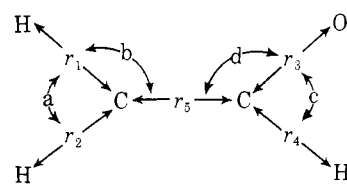

Parameter	Anion	Radical
r_1	1.115 Å	1.110 Å
r_2	1.115 Å	1.113 Å
r_3	1.311 Å	1.336 Å
r_4	1.142 Å	1.119 Å
r_5	1.354 Å	1.333 Å
a	110.6°	112.9°
b	125.5°	123.5°
c	114.5°	114.0°
d	131.7°	123.0°

possesses approximately 9 kcal/mol of translational energy.²⁵ Depending on the dynamics of proton transfer it is conceivable that this translational energy may be partially converted to internal energy in the product anion. To investigate the importance of hot bands at the photodetachment thresholds we generated some enolate anions using F⁻ generated from SO₂F₂. There is evidence²⁶ that F⁻ from SO₂F₂ possesses significantly less translational energy than that from NF₃. The thresholds using F⁻ from SO₂F₂ (in parentheses in Table I) seem to be shifted to shorter wavelength for the acetaldehyde, acetone, and pinacolone enolates. Since signal to noise is much poorer when SO₂F₂ rather than NF₃ is used as the F⁻ source, pinacolone enolate is the only anion for which this shift is outside experimental uncertainty. The apparent threshold shifts for acetaldehyde and acetone enolates could be due to poor signal to noise. However, even if the ions formed from NF₃ are hot, the true thresholds still appear to be within the experimental uncertainty, and we conclude that hot bands are not important in determining the electron affinities.

Electron Affinities. The observed thresholds which are presented in the first column of Table I are necessarily lower limits to the electron affinities of the enolate radicals. This conclusion is drawn because the calculated geometry changes in the acetaldehyde enolate system are not so extreme that the O-O vibrational transition will be too weak to observe. The relatively sharp nature of the threshold for acetaldehyde enolate anion indicates that in fact the O-O transition has quite large intensity. The other enolate anions show reasonable trends for substituent shifts in their thresholds, so while their Franck-Condon factors are presumably worse than those for acetaldehyde enolate, the O-O transition still has significant intensity. In addition if bond strengths of 98.0 ± 2.0 kcal/mol for a primary C-H bond strength²⁷ and 92.3 ± 1.4 kcal/mol for a secondary C-H bond strength²⁸ are used, with the known acidity of HF (DH°(H-F) - EA(F⁻) = 57.3 kcal/mol)²⁹ a lower limit may be set on the electron affinities of the enolate radicals. This limit is independent of the photodetachment results, and is obtained by noting that ΔG° is negative for proton abstraction from the parent carbonyl by F⁻. Neglecting entropy changes (which should decrease this lower limit by 1-2 kcal/mol) the lower limit is 40.7 ± 3.3 kcal/mol for the enolate radicals from methyl carbonyl compounds, and 35.0 ± 2.6 kcal/mol for those from carbonyl compounds which form secondary enolate radicals. The threshold energies corrected for the instrumental bandwidth, E₀ in Table I, are in consistent agreement with these lower limits.

The corrected thresholds are then identified as the electron affinities of the enolate radicals. This identification assumes relatively small contributions from hot bands at threshold.

Since small threshold shifts are observed when the energy available to the anions is varied, additional uncertainty in the electron affinities as a result of the hot bands will result. We have therefore not attempted to assign any electron affinities more accurately than the instrumental bandwidth, ± 24 nm, although each threshold determination has greater accuracy.

Acidities. The acidities of carbonyl compounds may be calculated by combining the electron affinities of enolate radicals with known C-H bond strengths in the parent carbonyl compounds. The C-H bond strength in acetone is 98.0 ± 2.0 kcal/mol,²⁷ and the secondary C-H bond strength in 2-butanone is 92.3 ± 1.4 kcal/mol.²⁸ These bond strengths give ΔH° for the acidity of acetone and 2-butanone as 371.0 ± 3.3 and 367.3 ± 2.6 kcal/mol, respectively. There is reasonable agreement between this value for the acidity of acetone and the ΔH° measured by Kebarle and co-workers of 369.2 ± 0.4 kcal/mol.³⁰ If the α -C-H bond strengths in acetophenone and pinacolone are assumed to be the same as in acetone, the electron affinities of the enolate radicals give an acidity order in the gas phase of acetone < pinacolone < acetophenone. Acidity measurements in polyether solutions with diarylamides give the ordering pinacolone < acetone < acetophenone.³ The low acidity of pinacolone relative to acetone in solution may be the result of steric hindrance to the solvation of pinacolone enolate anion. The reversal of these acidities in the gas phase indicates that solvent effects may play an important role in determining the relative acidities of ketones in solution.

Electronic Excitations. A feature of particular interest appears in the photodetachment cross sections of phenylacetaldehyde (Figure 4) and acetophenone enolate anions. In each of these cross sections an intense peak is observed, with a maximum at about 420 nm for acetophenone enolate and at about 340 nm for phenylacetaldehyde enolate. For acetaldehyde, acetone, and propionaldehyde enolate anions the cross section begins to rise sharply at about 400 nm, suggesting that a similar peak may exist further into the UV for these anions. It seems reasonable to identify these peaks with transitions to excited electronic states of the enolate anions followed by autodetachment. Features similar to these have been previously observed in the photodetachment cross sections of negative ions.³¹ These observations suggest the important application of photodetachment spectroscopy as a sensitive probe of the higher electronic states of negative ions. We are presently engaged in more detailed studies of this type of excitation.

Substituent Effects. If we can understand the relationship of structure and electron affinity (EA), we can couple this with our knowledge of structure and stability in neutrals to understand the acidities of carbonyl compounds. This is possible because the acidity is simply related to the difference between the C-H bond energy in the carbonyl compound and the EA of the enolate radical. As we shall see, the results we have obtained are more or less consistent with previously held generalizations. The usual key to understanding bond energies, electron affinities, and acidities is that enolate radicals look like simple localized carbon radicals, relatively unaffected by the adjacent carbonyl group, while enolate anions are best described as vinyl alkoxides. That is, the predominant resonance forms are a and b for the radical and anion, respectively. The evidence of this for the radical is the lack of appreciable resonance energy in these radicals.^{27,28} The results obtained in this work suggest that enolate anions are better described as highly delocalized. The evidence is of two types: the shape of the thresholds described above and the substituent effects



described below.

The substituent effects studied here can be divided into classes as described in the introduction: polar substituents not at the charged center, large vs. small substituents, and substitution at the charged center. The enolate ions are a particularly attractive group to examine because the carbonyl carbon is roughly at the nodal plane of the HOMO, while the α carbon has appreciable electron density in the HOMO. Because the parent compounds appear to follow group additivity rules and therefore have minimal resonance stabilization, it is useful to couch the discussion of substituent effects in terms of the stabilities of the enolate radicals and anions.

Not surprisingly, substitution of polar groups at the carbonyl carbon causes predictable changes in the EA's. Thus in the series $-\text{CH}_2\text{COZ}$, substitution for H of Z = CF_3 , F, phenyl increases the EA by 17.8, 9.5, and 5.9 kcal/mol, respectively. When Z = CH_3 the EA decreases slightly, consistent with the electron-donating effect of alkyls bonded to unsaturated carbon.³² When Z is a π -donating substituent such as F or OCH_3 the electronic description as a simple enolate is less appropriate, and indeed these substituents appear to be less stabilizing than expected on an inductive basis. Because we expect the noninteracting substituents to have little effect on DH° in the parent compound, the acidities should parallel the EA's.

Substitution of a large alkyl group for a small one at a position away from the charged center should tend to increase the EA slightly through increased polarizability.² This is observed in the series $-\text{CH}_2\text{COR}$, R = Me, Et, *t*-Bu. In all cases Me and Et are almost the same and *t*-Bu is stabilizing. The effects are slightly larger at the α as opposed to the carbonyl carbon, consistent with a polarizability model and substantial charge at the α carbon. In each of these series substitution should have little effect on ΔH° , so that again we predict a correlation of acidity with EA, as observed.¹⁴

Finally, we may make substitutions for H directly at the α carbon. Substitution of phenyl should cause an increase in EA and a lowering of DH° , thus dramatically increasing the acidity. Replacing H with CH_3 causes an EA decrease in aldehydes, methyl ketones, and ethyl ketones. This is the same kind of dipolar destabilization we observed in substituting CH_3 for H at the carbonyl carbon, but the effect is larger in this case: -2.8 kcal/mol for acetaldehyde vs. propionaldehyde; -1.1 kcal/mol for acetaldehyde vs. acetone. This result implies substantial negative charge on the α carbon. The bond energy lowering associated with this type of substitution is^{27,28} about 6 kcal/mol, so that the overall effect of the substitution on acidity is a slight increase as discussed above. In this situation much of the bond weakening effect due to substitution in the parent carbonyl arises from the often observed hybridization effect, C-C sp^2 - sp^3 bonds being more stable than C-H sp^2 - sp^3 bonds relative to the saturated systems. This effect is worth 2-3 kcal/mol and is about the same size as the inductive destabilizing effect of the methyl group.^{7c,33} Thus, it is difficult to predict a priori whether substitution of this type will increase or decrease acidity since the acidity trend is controlled by the relatively small differences between EA and DH° .

It is known that, in solution, substitution increases the acidity of ketones. For example, 1-methylcyclopentanone preferentially gives the more highly substituted enolate.³⁴ This effect is consistent with a view of enolates as vinyl alkoxides, a view reinforced by rapid protonation of these anions on oxygen.^{34,35} Our results suggest that these ions are quite delocalized, but the effects are intrinsic and not solution artifacts.

Conclusions

Photodetachment spectroscopy has been applied to a number of enolate anions. Electron affinities of the corresponding radicals have been determined from the thresholds. Substituent effects on these EA's have been determined and shown to agree

well with previously held generalizations and with solution behavior. The threshold shapes have been analyzed.

Acknowledgments. We thank Dr. Richard Finke for his aid in the synthesis of 3,3-dimethylbutanal, Dr. William Farneth for his aid in the synthesis of the deuterated 2-butanone, and Mr. John Garcia for technical assistance. We are grateful to the National Science Foundation for support of this work.

References and Notes

- (1) (a) NSF Predoctoral Fellow, 1973–1976; (b) Procter and Gamble Fellow; Eastman Kodak Fellow.
- (2) J. I. Brauman and L. K. Blair, *J. Am. Chem. Soc.*, **92**, 5986 (1970).
- (3) (a) H. D. Zook, W. L. Kelley, and I. Y. Posey, *J. Org. Chem.*, **33**, 3477 (1968); (b) R. G. Pearson and R. L. Dillon, *J. Am. Chem. Soc.*, **75**, 2439 (1953).
- (4) D. J. Cram, "Fundamentals of Carbanion Chemistry", Academic Press, New York, N.Y., 1965, pp 1–84.
- (5) T. B. McMahon and P. Kebarle, *J. Am. Chem. Soc.*, **98**, 3399 (1976).
- (6) J. R. Grunwell and J. F. Sebastian, *Tetrahedron*, **27**, 4387 (1971).
- (7) (a) J. I. Brauman, J. R. Eyler, L. K. Blair, M. J. White, M. B. Comisarow, and K. C. Smyth, *J. Am. Chem. Soc.*, **93**, 6360 (1971); (b) K. J. Reed and J. I. Brauman, *ibid.*, **97**, 1625 (1975); (c) J. H. Richardson, L. M. Stephenson, and J. I. Brauman, *J. Chem. Phys.*, **59**, 5068 (1973).
- (8) (a) K. C. Smyth and J. I. Brauman, *J. Chem. Phys.*, **56**, 1132 (1972); (b) *ibid.*, **56**, 4620 (1972); (c) *ibid.*, **56**, 5993 (1972).
- (9) (a) R. S. Berry and R. Millstein, *J. Chem. Phys.*, **55**, 4146 (1972); (b) A. Mandl, *Phys. Rev. A*, **3**, 251 (1971).
- (10) (a) J. L. Beauchamp and J. T. Armstrong, *Rev. Sci. Instrum.*, **40**, 123 (1969); (b) J. L. Beauchamp, *Annu. Rev. Phys. Chem.*, **22**, 527 (1971).
- (11) M. P. Cooke, *J. Am. Chem. Soc.*, **92**, 6080 (1970).
- (12) L. M. Stephenson, R. V. Gemmer, and S. P. Current, *J. Org. Chem.*, **42**, 212 (1977).
- (13) R. A. Cox and J. Warkentin, *Can. J. Chem.*, **50**, 3242 (1972).
- (14) W. E. Farneth and J. I. Brauman, *J. Am. Chem. Soc.*, **98**, 7891 (1976).
- (15) F. J. Davis, R. N. Compton, and D. R. Nelson, *J. Chem. Phys.*, **59**, 2324 (1973).
- (16) H. Hotop, T. A. Patterson, and W. C. Lineberger, *J. Chem. Phys.*, **60**, 1806 (1974).
- (17) (a) E. Herbst, T. A. Patterson, and W. C. Lineberger, *J. Chem. Phys.*, **61**, 1300 (1974); (b) K. J. Reed, A. H. Zimmerman, B. K. Janousek, and J. I. Brauman, manuscript in preparation.
- (18) W. C. Lineberger and B. W. Woodward, *Phys. Rev. Lett.*, **25**, 424 (1970).
- (19) K. J. Reed, A. H. Zimmerman, H. C. Andersen, and J. I. Brauman, *J. Chem. Phys.*, **64**, 1368 (1976).
- (20) E. P. Wigner, *Phys. Rev.*, **73**, 1002 (1948).
- (21) A. H. Zimmerman and J. I. Brauman, *J. Am. Chem. Soc.*, **99**, 3565 (1977).
- (22) The program CNINDO, Program 141, Quantum Chemistry Program Exchange, Department of Chemistry, Indiana University, Bloomington, Ind., was used for the calculations.
- (23) T. F. O'Malley, *Phys. Rev.*, **137**, 1668 (1965).
- (24) This is determined using average dipole orientation (ADO) theory and depends on the polarizability and dipole moment of each bath gas employed. See T. Su and M. T. Bowers, *J. Chem. Phys.*, **58**, 3027 (1973); T. Su and M. T. Bowers, *J. Am. Chem. Soc.*, **95**, 1370 (1973).
- (25) J. L. Franklin, *Science*, **193**, 725 (1976).
- (26) This conclusion is drawn since F^- from NF_3 readily abstracts a proton from *tert*-butyl and neopentyl alcohols, while F^- from SO_2F_2 does not abstract a proton from these alcohols with a significant rate. This has been observed by J. M. Riveros, University of São Paulo, São Paulo, Brazil (personal communication).
- (27) R. K. Solly, D. M. Golden, and S. W. Benson, *Int. J. Chem. Kinet.*, **2**, 11 (1970).
- (28) R. K. Solly, D. M. Golden, and S. W. Benson, *Int. J. Chem. Kinet.*, **2**, 381 (1970).
- (29) The electron affinity of fluorine is from ref 8a. The H–F bond dissociation energy is from S. W. Benson, *J. Chem. Educ.*, **42**, 502 (1965).
- (30) This value is 5.2 kcal/mol higher than that reported in ref 5: P. Kebarle, personal communication.
- (31) J. H. Richardson, L. M. Stephenson, and J. I. Brauman, *J. Am. Chem. Soc.*, **97**, 2967 (1975).
- (32) J. I. Brauman and L. K. Blair, *J. Am. Chem. Soc.*, **93**, 4315 (1971); R. Yamdagni and P. Kebarle, *ibid.*, **95**, 4050 (1973).
- (33) See J. Hine, "Structural Effects on Equilibria in Organic Chemistry", Wiley, New York, N.Y., 1975, p 181, for a discussion of this point.
- (34) See H. O. House, "Modern Synthetic Reactions", W. A. Benjamin, Menlo Park, Calif., 1972, p 501, for examples and a discussion of acidities and rates.
- (35) See ref 14 for a discussion of proton transfer rates of enolate anions.

Proton Exchange and Hydration in Photoexcited Naphthylamines and Naphthylammonium Ions

Stephen G. Schulman* and Roy J. Sturgeon

Contribution from the College of Pharmacy, University of Florida, Gainesville, Florida 32610. Received April 18, 1977

Abstract: The lack of reciprocity between the fluorometric pH titration curves of the naphthylamines and their conjugate acids is shown to be the result of static quenching of the cation emissions, resulting from hydration of the cations in the ground electronic state. The excited hydrated cations are shown to undergo protolytic dissociation, their extremely short-lived lowest excited singlet states notwithstanding.

The conversion of the blue fluorescence of 2-naphthylamine to the ultraviolet fluorescence of the corresponding naphthylammonium ion, in a pH region different from that in which the absorption spectrum of the neutral molecule was converted to that of the cation, was one of the earliest recorded examples of proton exchange in the lowest excited singlet state.¹ Subsequent studies of the pH dependencies of the fluorescence spectra of 2-naphthylamine^{2,3} and 1-naphthylamine³ indicated that excited-state proton exchange in these compounds was not simple, as suggested by the reaction

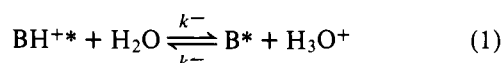

because the sums of the relative quantum yields of fluorescence of BH^{+*} and B^* did not equal unity at all points in the fluorometric titrations. Rather, the fluorescences of the neutral

molecules were quenched with decreasing pH, without the concomitant appearance of the fluorescences of the cations. The fluorescences of the cations appeared, to a significant extent, only in moderately concentrated mineral acid solutions where the fluorescences of the neutral molecules were unobservable. Moreover, the absorption spectra of the cations did not change appreciably in this region of Hammett acidity. It was hypothesized that quenching,² possibly due to the formation of hydrated exciplexes of the naphthylammonium ions³ was responsible for this unusual fluorometric titration behavior.

In order to further elucidate the nature of the anomalous fluorometric pH titration behavior of the naphthylamines and the naphthylammonium ions, the present reinvestigation of the pH and Hammett acidity dependencies of their fluorescence spectra was undertaken.